

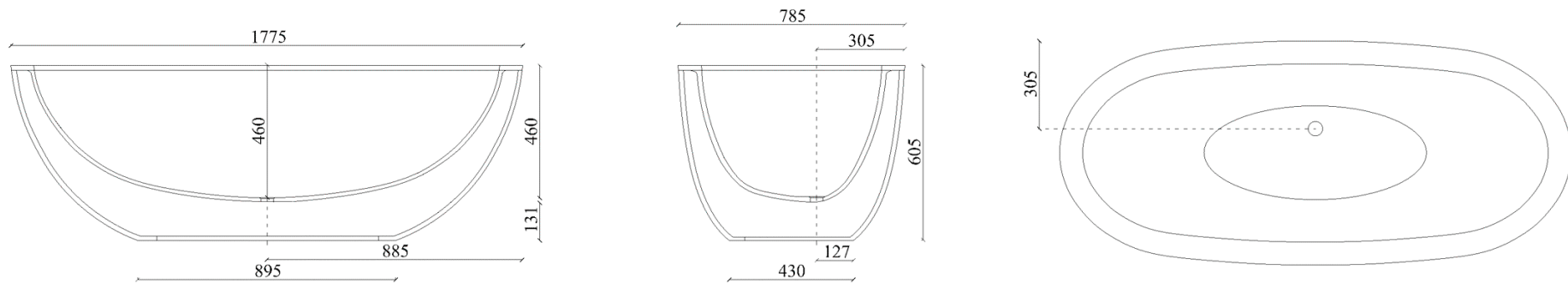

# MOLOKO BATH

## Installation instructions

DADO recommend that you use a qualified installer. Adhere to all instructions. We will not accept responsibility or incorrect instalation.



- 1**

Ensure that the drain pipe in the floor is thoroughly cleaned before the bath is placed into position and that the waste hole is positioned correctly.
- 2**

Before the bath is fixed to the floor ensure that the bath waste and the drainage pipe line up.
- 3**

Make sure all surfaces are dry and stable before installing the bathtub. This will ensure durable adhesion.
- 4**

Mark an area with tape on the floor where the bathtub is going to stand with the template provided, the floor can now be properly prepared.
- 5**

Position the bathtub and connect the waste, use a spirit level to ensure that the bathtub is level. Fill the bathtub with water, let the water run through the waste and check for leaks. Apply a bead of silicone around the base of the bathtub.

Dado recommends the product protection remains on the bathtub until all construction is complete. Drain and waste assembly not included and must be ordered separately.

## CARE AND MAINTENANCE

Wash our DADO bathware after installation with warm soapy water. To remove any marks left behind in the delivery and installation process. If a substance or stain is left on the surface, such as pen, essential oils or just simple soap or bath oils, use DADO surface cleaner in this case and for more aggressive cleaning DADO surface cleaner can be applied to tougher stains or marks. You can also use products like Jif, Handyandy or a similar product like Domestos. The properties of the material mean this cleaner will not damage the surface of the bathware.

If the bath is ever scratched it can be removed easily. Simply use "wet n dry 400 grit" sandpaper, apply with water and gently sand out the scratch. Clean the surface with acetone, applied with a white cloth.

## WARRANTY

DADO baths are warranted by the manufacturer against any manufacturing fault or defective materials for a period of 25 years from the date of purchase.

The manufacturer's liability under this warranty is limited to the repair or replacement of the bath, if defective in the opinion of the manufacturer or its representative.

This warranty can be invalidated if one or more of the following circumstances existed:

- The bath was installed in a manner not appropriate for the product.
- The bath was not properly used in the manner its was intended.
- Maintenance is carried out with unapproved cleaning materials.
- Continual application of water at temperatures above 65°C.
- The original purchase slip should be presented on claim of warranty.

The warranty does not cover:

- Normal wear and tear
- Any consequential loss resulting from a possible defect.
- Claims from any person or body who is not the original purchaser of the bath.
- Any tap ware supplied with the bath ware.

## MOLOKO BATH Installation instructions

### Dado Australia

PO Box 404  
Ormeau, QLD, 4208  
P: +61 (0) 7 5549 0504  
F: +61 (0) 7 5549 3170  
M: +61 (0) 4 5031 2461  
[www.dadoaustralia.com.au](http://www.dadoaustralia.com.au)

### Dado South Africa

PO Box 36407  
Menlo Park, PTA, 0102  
P: +27 (0)12 804 9338  
F: +27 (0)12 804 6746